

**SDX<sup>®</sup> THERMOBOX<sup>®</sup>**

*Keeping the right temperature*



# PRODUCT CATALOGUE

2021/2022

SDX<sup>®</sup> THERMOBOX<sup>®</sup> – THE ORIGINAL MADE IN SWEDEN SINCE 1969



## **SDX THERMOBOX**

We at SDX® Thermobox® have been a trustworthy partner professional caterers for more than 50 years. Our part of your job is to provide security. You can focus on the food and know that from the moment it leaves the kitchen until served, stored it in the best way. The fresh ingredients and good food must be good when served.

You should also feel safe in that the technology works. The temperature is exactly right and that the boxes can withstand the sometimes rugged treatment they may face.

## Correct temperature

The correct temperature is extremely important from a number of perspectives. Both to maintain the good quality and taste of the food, and to satisfy hygiene requirements.

To achieve this, the boxes are well insulated and equipped with digital temperature control to keep the temperature at the correct level during transport.



## Low energy consumption

To ensure the best insulation properties, the boxes are insulated with polyurethane, which expands under high pressure and combines the outer and inner containers to form a strong and well insulated unit.

This ensures that the food is stored at the correct temperature with a very low power consumption and low operating costs.



## Hygienic food handling

The completely stainless steel interior with no joints or recesses is the obvious choice for hygienic food handling. Pressed stainless steel guides, a unique technology that delivers unmatched durability, increase safety and simplify cleaning.



## Ergonomic and economic

The functional and straightforward design in combination with the free-rolling wheels makes transport from kitchen to diner simple and ergonomic.

An SDX® Thermobox® is designed to be compact and lightweight, which minimises the space required during both storage and transport. This saves both resources and the environment.





Smooth storage surface with the possibility for securing loads

Welded stainless steel inside containers with smooth surfaces, high durability and the best hygiene properties

The doors can be opened 270 degrees

Deep drawn guides, easy cleaning and increased safety

Short heating or cooling time

Air gaps for internal air circulation and even temperature distribution

Durable door gaskets

Electronically adjustable temperature control

Easy to clean for improved hygiene



Protective top frame

High energy efficiency means low operating costs

High-pressure isolation with polyurethane

Choice of door locks by function

Low overall weight

Recessed door for effective insulation

Stable reject list

Jetproof interior and exterior for easier cleaning

Compact space-efficient design

Can be equipped with a central brake

Durable 160mm easy rolling rubber wheels

















*Keeping the right temperature*

## A complete range for all your transport needs.

We offer a range of products spanning from the insulated S-box to advanced cooling and heating systems in the K- and F-boxes.



	<b>THERMOBOX® S - NEUTRAL THERMOBOX</b>	<b>8</b>
SDX can provide a full range of neutral thermobox options which include insulation only.		
	<b>THERMOBOX® C – ACTIVE COOLING</b>	<b>12</b>
Active cooling refrigeration for storing chilled food over longer periods of time.		
	<b>THERMOBOX® K – COMPRESSOR COOLING</b>	<b>16</b>
Extremely efficient compressor cooling accounts for the highest standards refrigeration.		
	<b>THERMOBOX® E – ELECTRIC HEATING</b>	<b>20</b>
Have an advanced heating system with extremely high reliability. It keeps the temperature within the desired values and with minimal temperature fluctuations.		
	<b>THERMOBOX® F – CONVECTION HEATING</b>	<b>26</b>
Convection heat with added value and many benefits! Short heating time. Hot air fan to compensate temperature losses. Flexible heating cabinet.		
	<b>THERMOBOX® – COMBINATIONS</b>	<b>30</b>
Transport and storage of both hot and chilled food in the same unit.		
	<b>THERMOBOX® BANQUET</b>	<b>44</b>
Transportation with GN2/1 Containers.		
	<b>THERMOBOX® – HEATING CABINET</b>	<b>46</b>
	<b>THERMOBOX® – OPTIONS AND ACCESSORIES</b>	<b>50</b>
	<b>PORTABEL THERMOBOX®</b>	<b>52</b>
	<b>TROLLEYS</b>	<b>53</b>
	<b>IDESTA CONTAINERS</b>	<b>54</b>



## THERMOBOX® S

A box that you cool down by putting it in a cold store or using the SDX® cooling plate.

The interior is made entirely of stainless steel with pressed guides and no joints. Insulated with polyurethane, which expands under high pressure and combines the outer and inner containers to form a strong and well insulated unit.

S-boxes are ideal for food that is to be served cold as well as for transporting and storing food that is to be heated at a later stage in the process.



### TECHNICAL SPECIFICATIONS

**Exterior walls:** ABS plastic.

**Inner container:** Welded container in stainless steel.

**Guides:** Stainless steel, pressed from the inner container.

**Insulation:** Polyurethane.

**Door:** Internal surface made of smooth and seamless stainless steel. Exterior in ABS plastic.

**Wheels:** 160 mm wheels, two braked and two fixed.

**Top frame:** Stainless steel and PVC corners.

**Trolley frame:** Reject list of stainless steel coated with PVC.

**S:** Neutral.



# THERMOBOX® S - NEUTRAL THERMOBOX

A full range of neutral thermobox options which include insulation only.

## S60

GUIDES    OUTER    INNER    WEIGHT

4 x GN 1/1  
80mm spacing

W: 525mm  
D: 700mm  
H: 870mm

w: 330mm  
D: 540mm  
H: 350mm

37 kg



**Product number:** 122005-ZS  
SDX Thermobox S60 (4 GN 1/1) Single handed grip handle

**Product number:** 122005-XS  
SDX Thermobox S60 (4 GN 1/1) Excenter lock

## S90

GUIDES    OUTER    INNER    WEIGHT

6 x GN 1/1  
80mm spacing

W: 525mm  
D: 700mm  
H: 1030mm

W: 330mm  
D: 540mm  
H: 510mm

41 kg



**Product number:** 122003-ZS  
SDX Thermobox S90 (6 GN 1/1) Single handed grip handle

**Product number:** 122003-XS  
SDX Thermobox S90 (6 GN 1/1) Excenter lock

## S120

GUIDES    OUTER    INNER    WEIGHT

8 x GN 1/1  
80mm spacing

W: 525mm  
D: 700mm  
H: 1190mm

W: 330mm  
D: 540mm  
H: 670mm

45 kg





**Product number:** 122039-ZS  
SDX Thermobox S120 (8 GN 1/1) Single handed grip handle

**Product number:** 122039-XS  
SDX Thermobox S120 (8 GN 1/1) Excenter lock

## THERMOBOX® S - NEUTRAL THERMOBOX

A full range of neutral thermobox options which include insulation only.

S150	GUIDES	OUTER	INNER	WEIGHT
	10 x GN 1/1 80mm spacing	W: 525mm D: 700mm H: 1155mm	B: 330mm D: 540mm H: 830mm	47 kg
	<p><b>Product number:</b> 122040-ZS SDX Thermobox S150 (10 GN 1/1) Single handed grip handle</p> <p><b>Product number:</b> 122040-XS SDX Thermobox S150 (10 GN 1/1) Excenter lock</p>			

S180	GUIDES	OUTER	INNER	WEIGHT
	12 x GN 1/1 80mm spacing	W: 525mm D: 700mm H: 1330mm	W: 330mm D: 540mm H: 1000mm	50 kg
	<p><b>Product number:</b> 122030-ZS SDX Thermobox S180 (12 GN 1/1) Single handed grip handle</p> <p><b>Product number:</b> 122030-XS SDX Thermobox S180 (12 GN 1/1) Excenter lock</p>			

SS180	GUIDES	OUTER	INNER	WEIGHT
	6 + 6 x GN 1/1 80mm spacing	W: 525mm D: 700mm H: 1420mm	W: 330mm D: 540mm H: 510+510mm	60 kg
	<p><b>Product number:</b> 122101-ZS SDX Thermobox SS180 (6+6 GN 1/1) Single handed grip handle</p> <p><b>Product number:</b> 122101-XS SDX Thermobox SS180 (6+6 GN 1/1) Excenter lock</p>			

# THERMOBOX® S - NEUTRAL THERMOBOX

A full range of neutral thermobox options which include insulation only.



14

## S210

	GUIDES	OUTER	INNER	WEIGHT
	14 x GN 1/1 80mm spacing	W: 525mm D: 700mm H: 1490mm	W: 330mm D: 540mm H: 1160mm	56 kg
	<p><b>Product number:</b> 122075-ZS SDX Thermobox S210 (14 GN 1/1) Single handed grip handle <i>Additional pull handles on the sides are included</i></p> <p><b>Product number:</b> 122075-XS SDX Thermobox S210 (14 GN 1/1) Excenterlås <i>Additional pull handles on the sides are included</i></p>			

## SS360

	GUIDES	OUTER	INNER	WEIGHT
	12 + 12 x GN 1/1 80mm spacing	W: 935mm D: 700mm H: 1330mm	W: 330+330mm D: 540mm H: 1000mm	100 kg
	<p><b>Product number:</b> 122045-ZS SDX Thermobox SS360 (12+12 GN 1/1) Single handed grip handle</p>			

12 | 12

## SSS540

	GUIDES	OUTER	INNER	WEIGHT
	12+12+12 x GN 1/1 80mm spacing	W: 1360mm D: 700mm H: 1330mm	W: 330+330+330mm D: 540mm H: 1000mm	150 kg
	<p><b>Product number:</b> 122055-ZS SDX Thermobox SSS540 (12+12+12 GN 1/1) Single handed grip handle</p>			

12 | 12 | 12



## THERMOBOX® C

A built-in cooling system with high operational reliability ensures active cooling to achieve the desired temperature. The temperature is easy to adjust to the desired level and can be read via a digital control unit.

The interior is made entirely of stainless steel with pressed guides and no joints. Insulated with polyurethane, which expands under high pressure and combines the outer and inner containers to form a strong and well insulated unit.

C-boxes are ideal for food that is to be served cold as well as for transporting and storing food that is to be heated at a later stage in the process.



### TECHNICAL SPECIFICATIONS

**Exterior walls:** ABS plastic.

**Inner container:** Welded container in stainless steel.

**Guides:** Stainless steel, pressed from the inner container.

**Insulation:** Polyurethane.

**Door:** Internal surface made of smooth and seamless stainless steel. Exterior in ABS plastic.

**Wheels:** 160 mm wheels, two braked and two fixed.

**Top frame:** Stainless steel and PVC corners.

**Trolley frame:** Rejact list of stainless steel coated with PVC.

**C:** Efficient compact chillers with electronic temperature control AA120, 27V DC. 230V/245W AC, insulation class IP44.

# THERMOBOX® C – ACTIVE COOLING

Active cooling refrigeration for storing chilled food over longer periods of time.



4

6

8

10

## C60



GUIDES	OUTER	INNER	WEIGHT
4 x GN 1/1 80mm spacing	W: 525mm D: 810mm H: 895mm	W: 330mm D: 540mm H: 350mm	51 kg
<p><b>Product number:</b> 122206-ZC SDX Thermobox C60 (4 GN 1/1) Single handed grip handle</p> <p><b>Product number:</b> 122206-XC SDX Thermobox C60 (4 GN 1/1) Excenter lock</p>			

## C90



GUIDES	OUTER	INNER	WEIGHT
6 x GN 1/1 80mm spacing	W: 525mm D: 810mm H: 1055mm	W: 330mm D: 540mm H: 510mm	56 kg
<p><b>Product number:</b> 122207-ZC SDX Thermobox C90 (6 GN 1/1) Single handed grip handle</p> <p><b>Product number:</b> 122207-XC SDX Thermobox C90 (6 GN 1/1) Excenter lock</p>			

## C120



GUIDES	OUTER	INNER	WEIGHT
8 x GN 1/1 80mm spacing	W: 525mm D: 810mm H: 1215mm	W: 330mm D: 540mm H: 670mm	60 kg
<p><b>Product number:</b> 122205-ZC SDX Thermobox C120 (8 GN 1/1) Single handed grip handle</p> <p><b>Product number:</b> 122205-XC SDX Thermobox C120 (8 GN 1/1) Excenter lock</p>			

## C150



GUIDES	OUTER	INNER	WEIGHT
10 x GN 1/1 80mm spacing	W: 525mm D: 825mm H: 1180mm	W: 330mm D: 540mm H: 830mm	65 kg
<p><b>Product number:</b> 122208-ZC SDX Thermobox C150 (10 GN 1/1) Single handed grip handle</p> <p><b>Product number:</b> 122208-XC SDX Thermobox C150 (10 GN 1/1) Excenter lock</p>			



# THERMOBOX® C – ACTIVE COOLING

Active cooling refrigeration for storing chilled food over longer periods of time.

12

C180	GUIDES	OUTER	INNER	WEIGHT
	12 x GN 1/1 80mm spacing	W: 525mm D: 825mm H: 1355mm	W: 330mm D: 540mm H: 1000mm	70 kg
	<p><b>Product number:</b> 122200-ZC SDX Thermobox C180 (12 GN 1/1) Single handed grip handle</p> <p><b>Product number:</b> 122200-XC SDX Thermobox C180 (12 GN 1/1) Excenter lock</p>			

14

C210	GUIDES	OUTER	INNER	WEIGHT
	14 x GN 1/1 80mm spacing	W: 525mm D: 825mm H: 1515mm	W: 330mm D: 540mm H: 1160mm	75 kg
	<p><b>Product number:</b> 122209-ZC SDX Thermobox C210 (14 GN 1/1) Single handed grip handle <i>Additional pull handles on the sides are included</i></p> <p><b>Product number:</b> 122209-XC SDX Thermobox C210 (14 GN 1/1) Excenter lock <i>Additional pull handles on the sides are included</i></p>			

88

CC240	GUIDES	OUTER	INNER	WEIGHT
	8+8 x GN 1/1 80mm spacing	W: 935mm D: 810mm H: 1215mm	W: 330+330mm D: 540mm H: 670mm	120 kg
	<p><b>Product number:</b> 122320-ZC SDX Thermobox CC240 (8+8 GN 1/1) Single handed grip handle</p>			

# THERMOBOX® C – ACTIVE COOLING

Active cooling refrigeration for storing chilled food over longer periods of time.



## CC360



GUIDES	OUTER	INNER	WEIGHT
12+12 x GN 1/1 80mm spacing	W: 935mm D: 825mm H: 1355mm	W: 330+330mm D: 540mm H: 1000mm	140 kg
<p><b>Product number:</b> 122201-ZC SDX Thermobox CC360 (12+12 GN 1/1) Single handed grip handle</p>			

12 | 12

## CC420



GUIDES	OUTER	INNER	WEIGHT
14+14 x GN 1/1 80mm spacing	W: 935mm D: 825mm H: 1515mm	W: 330+330mm D: 540mm H: 1160mm	150 kg
<p><b>Product number:</b> 122265-ZC SDX Thermobox CC420 (14+14 GN 1/1) Single handed grip handle</p>			

14 | 14

## CCC540



GUIDES	OUTER	INNER	WEIGHT
12+12+12 x GN 1/1 80mm spacing	W: 1360mm D: 825mm H: 1355mm	W: 330+330+330mm D: 540mm H: 1000mm	210 kg
<p><b>Product number:</b> 122266-ZC SDX Thermobox CCC540 (12+12+12 GN 1/1) Single handed grip handle</p>			

12 | 12 | 12



# Reducing the Environmental Impact of Food Transport

## A new generation of refrigerated containers for a sustainable future

### **THERMOBOX® K ECO**

The new generation of compressor-based refrigerated containers from SDX represents a giant leap forward in the development of compressor cooling technology. The K-boxes comprise a completely new refrigeration unit featuring the eco-friendly refrigerant R290A. Lower total height and weight. New, highly efficient RPM-controlled fans, where the noise level has been halved to improve the working environment. Just like previous generations, the inside is made completely of stainless steel, with pressed guides and no joins. There is a digital control unit on the top edge of the box to facilitate setting and monitoring the temperature of the container.

K-boxes are excellent for food that is to be served cold, and for transporting and storing food that is to be heated up subsequently.



## THERMOBOX® K ECO – COMPRESSOR COOLING

Extremely efficient compressor cooling accounts for the highest standards refrigeration.



### HEIGHT

Reduced by approx. 50 mm.

### INSULATION

Die-cast, join-free PUR with low  $\lambda$ -value.

### REFRIGERANT

R290a. Insignificant environmental impact (GWP 3).

### NOISE

A 50% reduction in the perceived noise level provides an improved working environment.

### FANS

Latest motor technology, efficiency of 70–80%.

### WEIGHT

Reduced total weight.

## TECHNICAL SPECIFICATIONS

**Exterior walls:** ABS plastic.

**Inner container:** Welded container in stainless steel.

**Guides:** Stainless steel, pressed from the inner container.

**Insulation:** Polyurethane.

**Door:** Internal surface made of smooth and seamless stainless steel. Exterior in ABS plastic.

**Wheels:** 160 mm wheels, two braked and two fixed.

**Top frame:** Stainless steel and PVC corners.

**Trolley frame:** Reject list of stainless steel coated with PVC.

**K:** Efficient compressor refrigeration. Eco-friendly refrigerant (R290A) Low-noise, RPM-controlled fans. Digital temperature regulation. 230V/190W

# THERMOBOX® K ECO – COMPRESSOR COOLING

Extremely efficient compressor cooling accounts for the highest standards refrigeration.

4

K60 ECO	GUIDES	OUTER	INNER	WEIGHT
	4 x GN 1/1 80mm spacing	W: 525mm D: 750mm H: 925mm	W: 330mm D: 540mm H: 350mm	65 kg
	<p><b>Product number:</b> 122206-ZK SDX Thermobox K60 ECO (4 GN 1/1) Single handed grip handle</p> <p><b>Product number:</b> 122206-XK SDX Thermobox K90 ECO (4 GN 1/1) Excenter lock</p>			

6

K90 ECO	GUIDES	OUTER	INNER	WEIGHT
	6 x GN 1/1 80mm spacing	W: 525mm D: 750mm H: 1085mm	B: 330mm D: 540mm H: 510mm	70 kg
	<p><b>Product number:</b> 122207-ZK SDX Thermobox K90 ECO (6 GN 1/1) Single handed grip handle</p> <p><b>Product number:</b> 122207-XK SDX Thermobox K90 ECO (6 GN 1/1) Excenter lock</p>			

8

K120 ECO	GUIDES	OUTER	INNER	WEIGHT
	8 x GN 1/1 80mm spacing	W: 525mm D: 750mm H: 1245mm	W: 330mm D: 540mm H: 670mm	75 kg
	<p><b>Product number:</b> 122205-ZK SDX Thermobox K120 ECO (8 GN 1/1) Single handed grip handle</p> <p><b>Product number:</b> 122205-XK SDX Thermobox K120 ECO (8 GN 1/1) Excenter lock</p>			



# THERMOBOX® K ECO – COMPRESSOR COOLING

Extremely efficient compressor cooling accounts for the highest standards refrigeration.



10

12

14

## K150 ECO

	GUIDES	OUTER	INNER	WEIGHT
	10 x GN 1/1 80mm spacing	W: 525mm D: 770mm H: 1400mm	W: 330mm D: 540mm H: 830mm	80 kg
	<p><b>Product number:</b> 122208-ZK SDX Thermobox K150 ECO (10 GN 1/1) Single handed grip handle</p> <p><b>Product number:</b> 122208-XK SDX Thermobox K150 ECO (10 GN 1/1) Excenter lock</p>			

## K180 ECO

	GUIDES	OUTER	INNER	WEIGHT
	12 x GN 1/1 80mm spacing	W: 525mm D: 770mm H: 1575mm	W: 330mm D: 540mm H: 1000mm	85 kg
	<p><b>Product number:</b> 122270-ZK SDX Thermobox K180 ECO (12 GN 1/1) Single handed grip handle <i>Additional pull handles on the sides are included</i></p> <p><b>Product number:</b> 122270-XK SDX Thermobox K180 ECO (12 GN 1/1) Excenter lock <i>Additional pull handles on the sides are included</i></p>			

## K210 ECO

	GUIDES	OUTER	INNER	WEIGHT
	14 x GN 1/1 80mm spacing	W: 525mm D: 770mm H: 1735mm	W: 330mm D: 540mm H: 1160mm	90 kg
	<p><b>Product number:</b> 122209-ZK SDX Thermobox K180 ECO (14 GN 1/1) Single handed grip handle <i>Additional pull handles on the sides are included</i></p> <p><b>Product number:</b> 122209-XK SDX Thermobox K180 ECO (14 GN 1/1) Excenter lock <i>Additional pull handles on the sides are included</i></p>			



## THERMOBOX® E

Has an efficient heating system with high operational reliability that heats the box up to the desired temperature. The temperature is easy to adjust and read via a digital control unit.

The interior is made entirely of stainless steel with pressed guides and no joints. Insulated with polyurethane, which expands under high pressure and combines the outer and inner containers to form a strong and well insulated unit.

E-boxes are ideal for storing hot food and preserving the quality of the food during transport.



### TECHNICAL SPECIFICATIONS

**Exterior walls:** ABS plastic.

**Inner container:** Welded container in stainless steel.

**Guides:** Stainless steel, pressed from the inner container.

**Insulation:** Polyurethane.

**Door:** Internal surface made of smooth and seamless stainless steel. Exterior in ABS plastic

**Wheels:** 160 mm wheels, two braked and two fixed.

**Top frame:** Stainless steel and PVC corners.

**Trolley frame:** Reject list of stainless steel coated with PVC.

**E:** Heating system with digital temperature regulation, foil heating element, insulation class IP 44.

Have an advanced heating system with extremely high reliability. It keeps the temperature within the desired values and with minimal temperature fluctuations.

**E60**

	GUIDES	OUTER	INNER	WEIGHT
	4 x GN 1/1 80mm spacing	W: 525mm D: 700mm H: 895mm	W: 330mm D: 540mm H: 350mm	41 kg
	230V/280W <b>Product number:</b> 122006-ZE SDX Thermobox E60 (4 GN 1/1) Single handed grip handle  <b>Product number:</b> 122006-XE SDX Thermobox E60 (4 GN 1/1) Excenter lock			

**E90**

	GUIDES	OUTER	INNER	WEIGHT
	6 x GN 1/1 80mm spacing	W: 525mm D: 700mm H: 1055mm	W: 330mm D: 540mm H: 510mm	45 kg
	230V/650W <b>Product number:</b> 122004-ZE SDX Thermobox E90 (6 GN 1/1) Single handed grip handle  <b>Product number:</b> 122004-XE SDX Thermobox E90 (6 GN 1/1) Excenter lock			

**E120**

	GUIDES	OUTER	INNER	WEIGHT
	8 x GN 1/1 80mm spacing	W: 525mm D: 700mm H: 1215mm	W: 330mm D: 540mm H: 670mm	48 kg
	230V/650W <b>Product number:</b> 122027-ZE SDX Thermobox E120 (8 GN 1/1) Single handed grip handle  <b>Product number:</b> 122027-XE SDX Thermobox E120 (8 GN 1/1) Excenter lock			

**EE120**

	GUIDES	OUTER	INNER	WEIGHT
	4+4 x GN 1/1 80mm spacing	W: 525mm D: 700mm H: 1310mm	W: 330mm D: 540mm H: 350+350mm	54 kg
	2 x 230V/280W <b>Product number:</b> 122013-ZE SDX Thermobox EE120 (4+4 GN 1/1) Single handed grip handle  <b>Product number:</b> 122013-XE SDX Thermobox EE120 (4+4 GN 1/1) Excenter lock			

## THERMOBOX® E – ELECTRIC HEATING

Have an advanced heating system with extremely high reliability. It keeps the temperature within the desired values and with minimal temperature fluctuations.

EE150	GUIDES	OUTER	INNER	WEIGHT
	6+4 x GN 1/1 80mm spacing	W: 525mm D: 700mm H: 1285mm	W: 330mm D: 540mm H: 350+350mm	56 kg
	230V/650W + 230V/280W <b>Product number:</b> 122062-ZE SDX Thermobox EE150 (6+4 GN 1/1) Single handed grip handle  <b>Produktnummer:</b> 122062-XE SDX Thermobox EE150 (6+4 GN 1/1) Excenter lock			

E180	GUIDES	OUTER	INNER	WEIGHT
	12 x GN 1/1 80mm spacing	W: 525mm D: 700mm H: 1355mm	W: 330mm D: 540mm H: 1000mm	60 kg
	230V/800W <b>Product number:</b> 122033-ZE SDX Thermobox E180 (12 GN 1/1) Single handed grip handle  <b>Product number:</b> 122033-XE SDX Thermobox E180 (12 GN 1/1) Excenter lock			

EE180	GUIDES	OUTER	INNER	WEIGHT
	8+4 x GN 1/1 80mm spacing	W: 525mm D: 700mm H: 1445mm	W: 330mm D: 540mm H: 670+350mm	60 kg
	230V/650W + 230V/280W <b>Product number:</b> 122104-ZE SDX Thermobox EE180 (8+4 GN 1/1) Single handed grip handle  <b>Product number:</b> 122104-XE SDX Thermobox EE180 (8+4 GN 1/1) Excenter lock			

EE180	GUIDES	OUTER	INNER	WEIGHT
	6+6 x GN 1/1 80mm spacing	W: 525mm D: 700mm H: 1445mm	W: 330mm D: 540mm H: 510+510mm	70 kg
	230V/650W + 230V/650W <b>Product number:</b> 122102-ZE SDX Thermobox EE180 (6+6 GN 1/1) Single handed grip handle  <b>Product number:</b> 122102-XE SDX Thermobox EE180 (6+6 GN 1/1) Excenter lock			

Have an advanced heating system with extremely high reliability. It keeps the temperature within the desired values and with minimal temperature fluctuations.

**EE210**



GUIDES	OUTER	INNER	WEIGHT
8+6 GN 1/1 80mm spacing	W: 525mm D: 700mm H: 1605mm	W: 330mm D: 540mm H: 670+510mm	74 kg
230V/650W + 230V/650W <b>Product number:</b> 122155-ZE SDX Thermobox EE210 (8+6 GN 1/1) Single handed grip handle <i>Additional pull handles on the sides are included</i>  <b>Product number:</b> 122155-XE SDX Thermobox EE210 (8+6 GN 1/1) Excenter lock <i>Additional pull handles on the sides are included</i>			

**EE240**



GUIDES	OUTER	INNER	WEIGHT
8+8 x GN 1/1 80mm spacing	W: 930mm D: 700mm H: 1215mm	W: 330+330mm D: 540mm H: 670mm	96 kg
2 x 230V/650W <b>Product number:</b> 122132-ZE SDX Thermobox EE240 (8+8 GN 1/1) Single handed grip handle			

**EE360**



GUIDES	OUTER	INNER	WEIGHT
12+12 x GN 1/1 80mm spacing	W: 930mm D: 700mm H: 1355mm	W: 330+330mm D: 540mm H: 1000mm	120 kg
2 x 230V/800W <b>Product number:</b> 122048-ZE SDX Thermobox EE360 (12+12 GN 1/1) Single handed grip handle			

**EEE540**



GUIDES	OUTER	INNER	WEIGHT
12+12+12 x GN 1/1 80mm spacing	W: 1360mm D: 700mm H: 1355mm	W: 330+330+330mm D: 540mm H: 1000mm	180 kg
3 x 230V/800W <b>Product number:</b> 122050-ZE SDX Thermobox EEE540 (12+12+12 GN 1/1) Single handed grip handle			



### **A CLASSIC IN ANALOGUE DESIGN**

F180 is and has been a true servant in many commercial kitchens for several years. We now offer this model in an updated Classic design for you who are looking for an affordable alternative.

Their reliable heating system ensures good food hygiene and efficient food transport. Combined with very efficient insulation, this ensures both low operating costs and a food quality that is evident from the appreciation of diners. As with all our boxes, they have a robust and stable design.

---



**E180 CLASSIC**



GUIDES	OUTER	INNER	WEIGHT
12 x GN 1/1 80mm spacing	W: 525mm D: 700mm H: 1330mm	W: 330mm D: 540mm H: 1000mm	65 kg
<p>230V/1000W  <b>Produktnummer:</b> 122098-ZCL                      SDX Thermobox F180 Classic (12 GN 1/1) Single handed grip handle</p> <p><b>Product number:</b> 122099-XCL                      SDX Thermobox F180 Classic (12 GN 1/1) Excenter lock</p>			
<p><b>TECHNICAL SPECIFICATIONS</b></p> <p><b>Exterior walls:</b> ABS plastic.</p> <p><b>Inner container:</b> Welded container in stainless steel.</p> <p><b>Guides:</b> Stainless steel, pressed from the inner container.</p>		<p><b>Insulation:</b> Polyurethane.</p> <p><b>Door:</b> Interior made of stainless steel. ABS plastic exterior.</p> <p><b>Thermometer:</b> Analog.</p> <p><b>Wheels:</b> 160 mm wheels, two braked and two fixed.</p>	<p><b>Top frame:</b> Stainless steel and PVC corners.</p> <p><b>Trolley frame:</b> Reject list of stainless steel coated with PVC.</p> <p><b>F:</b> Efficient convection heating system, with electronic temperature control, insulation class IP 44, 230V/1000W.</p>

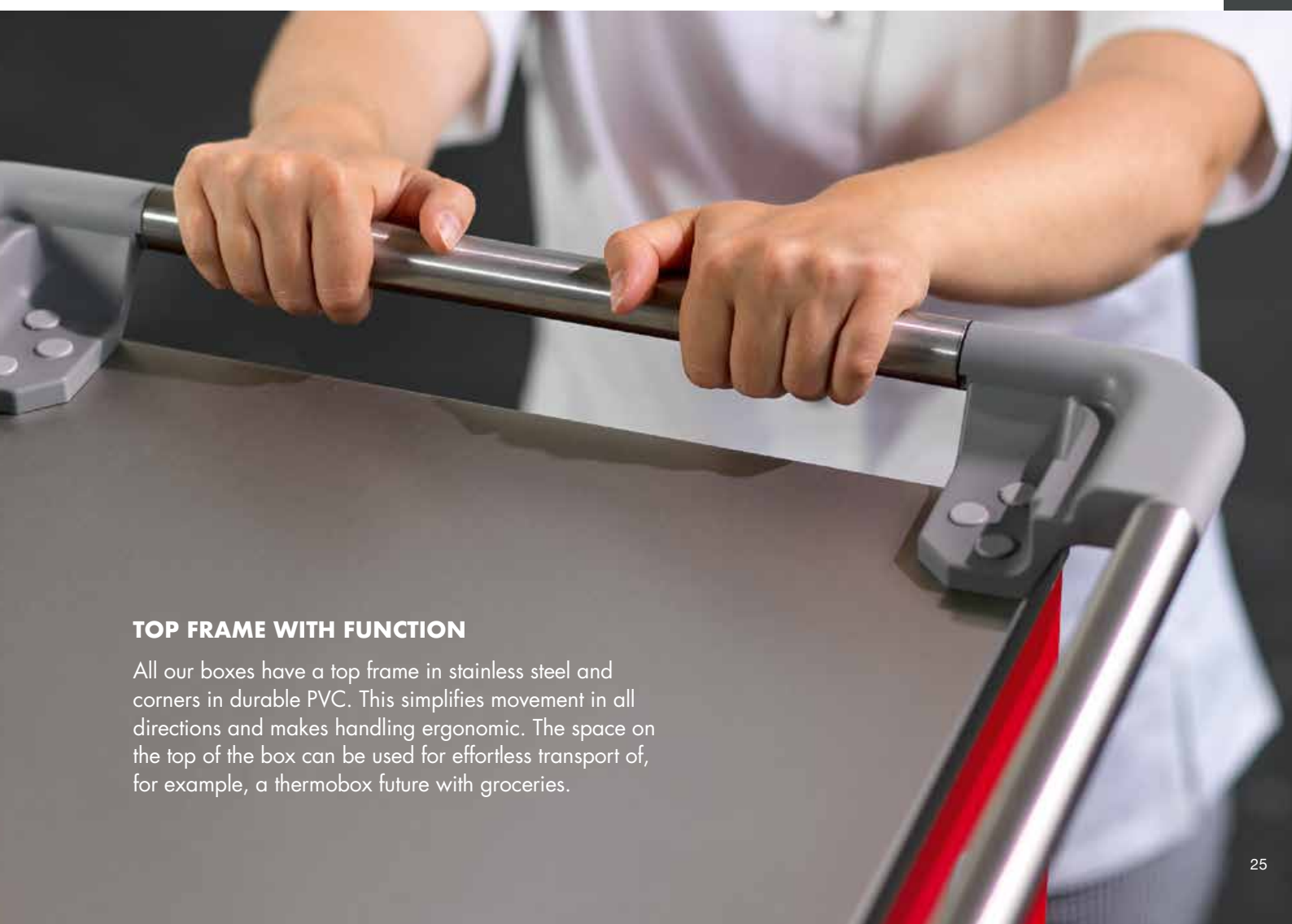

**TOP FRAME WITH FUNCTION**

All our boxes have a top frame in stainless steel and corners in durable PVC. This simplifies movement in all directions and makes handling ergonomic. The space on the top of the box can be used for effortless transport of, for example, a thermobox future with groceries.



## THERMOBOX® F

With efficient convection heating and hot-air fans to maintain a uniform temperature throughout the box. The flow of hot air forms a buffer around the food, which compensates for undesirable heat losses. The temperature is easy to adjust to the desired level and can be read via a digital control unit.

The interior is made entirely of stainless steel with pressed guides and no joints. Insulated with polyurethane, which expands under high pressure and combines the outer and inner containers to form a strong and well insulated unit.

F-boxes are ideal for storing hot food where the quality of the food is maintained during transport.



### TECHNICAL SPECIFICATIONS

**Exterior walls:** ABS plastic.

**Inner container:** Welded container in stainless steel.

**Guides:** Stainless steel, pressed from the inner container.

**Insulation:** Polyurethane.

**Door:** Internal surface made of smooth and seamless stainless steel. Exterior in ABS plastic.

**Wheels:** 160 mm wheels with rubber tires, two braked and two fixed.

**Top frame:** Stainless steel and PVC corners.

**Trolley frame:** Rejected list of stainless steel coated with PVC.

**F:** Efficient convection heating system, with electronic temperature control, insulation class IP 44, 230V/1000W.

## THERMOBOX® F – CONVECTION HEATING

Convection heat with added value and many benefits! Short heating time. Hot air fan to compensate temperature losses. Flexible heating cabinet.

F

### F60

	GUIDES	OUTER	INNER	WEIGHT
	4 x GN 1/1 80mm spacing	W: 525mm D: 750mm H: 895mm	W: 330mm D: 540mm H: 350mm	51 kg
	230V/550W <b>Product number:</b> 122006-ZF SDX Thermobox F60 (4 GN 1/1) Single handed grip handle  <b>Product number:</b> 122006-XF SDX Thermobox F60 (4 GN 1/1) Excenter lock			

### F90

	GUIDES	OUTER	INNER	WEIGHT
	6 x GN 1/1 80mm spacing	W: 525mm D: 750mm H: 1055mm	W: 330mm D: 540mm H: 510mm	54 kg
	230V/550W <b>Product number:</b> 122004-ZF SDX Thermobox F90 (6 GN 1/1) Single handed grip handle  <b>Product number:</b> 122004-XF SDX Thermobox F90 (6 GN 1/1) Excenter lock			

### F120

	GUIDES	OUTER	INNER	WEIGHT
	8 x GN 1/1 80mm spacing	W: 525mm D: 750mm H: 1215mm	W: 330mm D: 540mm H: 670mm	57 kg
	230V/550W <b>Product number:</b> 122027-ZF SDX Thermobox F120 (8 GN 1/1) Single handed grip handle  <b>Product number:</b> 122027-XF SDX Thermobox F120 (8 GN 1/1) Excenter lock			

### F150

	GUIDES	OUTER	INNER	WEIGHT
	10 x GN 1/1 80mm spacing	W: 525mm D: 770mm H: 1180mm	W: 330mm D: 540mm H: 830mm	61 kg
	230V/1000W <b>Product number:</b> 122064-ZF SDX Thermobox F150 (10 GN 1/1) Single handed grip handle  <b>Product number:</b> 122064-XF SDX Thermobox F150 (10 GN 1/1) Excenter lock			

4

6

8

10

# THERMOBOX® F – CONVECTION HEATING

Convection heat with added value and many benefits! Short heating time. Hot air fan to compensate temperature losses. Flexible heating cabinet.

12

F180	GUIDES	OUTER	INNER	WEIGHT
	12 x GN 1/1 80mm spacing	W: 525mm D: 770mm H: 1355mm	W: 330mm D: 540mm H: 1000mm	65 kg
	230V/1000W <b>Product number:</b> 122033-ZF SDX Thermobox F180 (12 GN 1/1) Single handed grip handle  <b>Product number:</b> 122033-XF SDX Thermobox F180 (12 GN 1/1) Excenter lock			

6  
6

FF180	GUIDES	OUTER	INNER	WEIGHT
	6+6 x GN 1/1 80mm spacing	W: 525mm D: 750mm H: 1445mm	W: 330mm D: 540mm H: 510+510mm	65 kg
	2x230V/550W <b>Product number:</b> 122134-ZF SDX Thermobox FF180 (6+6 GN 1/1) Single handed grip handle  <b>Product number:</b> 122134-XF SDX Thermobox FF180 (6+6 GN 1/1) Excenter lock			

14

F210	GUIDES	OUTER	INNER	WEIGHT
	14 x GN 1/1 80mm spacing	W: 525mm D: 770mm H: 1515mm	W: 330mm D: 540mm H: 1160mm	70 kg
	230V/1000W <b>Product number:</b> 122070-ZF SDX Thermobox F210 (14 GN 1/1) Single handed grip handle <i>Additional pull handles on the sides are included</i>  <b>Product number:</b> 122070-XF SDX Thermobox F210 (14 GN 1/1) Excenter lock <i>Additional pull handles on the sides are included</i>			

6  
8

FF210	GUIDES	OUTER	INNER	WEIGHT
	8+6 x GN 1/1 80mm spacing	W: 525mm D: 750mm H: 1605mm	W: 330mm D: 540mm H: 670+510mm	70 kg
	2 x 230V/550W <b>Product number:</b> 122135-ZF SDX Thermobox FF210 (8+6 GN 1/1) Single handed grip handle <i>Additional pull handles on the sides are included</i>  <b>Product number:</b> 122135-XF SDX Thermobox FF210 (8+6 GN 1/1) Excenter lock <i>Additional pull handles on the sides are included</i>			



## THERMOBOX® F – CONVECTION HEATING

Convection heat with added value and many benefits! Short heating time. Hot air fan to compensate temperature losses. Flexible heating cabinet.



### FF240



GUIDES	OUTER	INNER	WEIGHT
8+8 x GN 1/1 80mm spacing	W: 930mm D: 750mm H: 1215mm	W: 330+330mm D: 540mm H: 670+670mm	110 kg
2 x 230V/550W <b>Product number:</b> 122132-ZF SDX ThermoBox FF240 (8+8 GN 1/1) Single handed grip handle			

### FF360



GUIDES	OUTER	INNER	WEIGHT
12+12 x GN 1/1 80mm spacing	W: 930mm D: 770mm H: 1355mm	W: 330+330mm D: 540mm H: 1000mm	130 kg
2 x 230V/1000W <b>Product number:</b> 122048-ZF SDX ThermoBox FF360 (12+12 GN 1/1) Single handed grip handle			

### FF420



GUIDES	OUTER	INNER	WEIGHT
14+14 x GN 1/1 80mm spacing	W: 930mm D: 770mm H: 1515mm	W: 330+330mm D: 540mm H: 1160mm	140 kg
2 x 230V/1000W <b>Product number:</b> 122057-ZF SDX ThermoBox FF420 (14+14 GN 1/1) Single handed grip handle			

### FFF540



GUIDES	OUTER	INNER	WEIGHT
12+12+12 x GN 1/1 80mm spacing	W: 1360mm D: 770mm H: 1355mm	W: 330+330+330mm D: 540mm H: 1000mm	195 kg
3 x 230V/1000W <b>Product number:</b> 122136-ZF SDX ThermoBox FFF540 (12+12+12 GN 1/1) Single handed grip handle			

12 | 12



14 | 14

12 | 12 | 12

**A SUCCESSFUL COMBINATION!**

To meet different needs, SDX® has many solutions for a successful combination with cooling and heating in the same Thermobox® with or without active cooling or electronic heating. All variants have the renowned quality of SDX® and contains all-stainless steel interiors i.e. pressed guides in stainless inner receptacles.



	<p><b>THERMOBOX® SE</b></p> <p>Neutral and electric heating combination.</p>	<b>32</b>
	<p><b>THERMOBOX® SF</b></p> <p>Neutral and convection heating combination.</p>	<b>34</b>
	<p><b>THERMOBOX® CE</b></p> <p>Activ cooling and electric heating combination.</p>	<b>36</b>
	<p><b>THERMOBOX® CF</b></p> <p>Activ cooling and convection heating combination.</p>	<b>38</b>
	<p><b>THERMOBOX® KE</b></p> <p>Compressor cooling ECO and electric heating combination.</p>	<b>40</b>
	<p><b>THERMOBOX® KF</b></p> <p>Compressor cooling ECO and convection heating combination.</p>	<b>42</b>

## MAKE YOUR OWN COMBINATION

If you are struggling to find the perfect combination for your needs we can help you combine your own Thermobox®. We can combine all our modules from the smallest volume with 4 guides to our largest volume with 14 guides.

Please contact us about your food transportation needs and we will give you the solution.





## THERMOBOX® SE

**Exterior walls:** ABS plastic.

**Inner container:** Welded container in stainless steel.

**Guides:** Stainless steel, pressed from the inner container.

**Insulation:** Polyurethane.

**Door:** Internal surface made of smooth and seamless stainless steel. Exterior in ABS plastic.

**Wheels:** 160 mm wheels, two braked and two fixed.

**Top frame:** Stainless steel and PVC corners.

**Trolley frame:** Rejact list of stainless steel coated with PVC.

**S:** Neutral

**E:** Heating system, with electronic temperature control  
Foil elements, insulation class IP 44.

### SE120



GUIDES	OUTER	INNER S	INNER E	WEIGHT
4+4 x GN 1/1 80mm spacing	W: 525mm D: 700mm H: 1310mm	W: 330mm D: 540mm H: 350mm	W: 330mm D: 540mm H: 350mm	52 kg
Neutral + 230V/280W <b>Product number:</b> 122010-ZSE SDX Thermobox SE120 (4+4 GN 1/1) Single handed grip handle  <b>Product number:</b> 122010-XSE SDX Thermobox SE120 (4+4 GN 1/1) Excenter lock				

### SE150



GUIDES	OUTER	INNER S	INNER E	WEIGHT
4+6 x GN 1/1 80mm spacing	W: 525mm D: 700mm H: 1285mm	W: 330mm D: 540mm H: 350mm	W: 330mm D: 540mm H: 510mm	56 kg
Neutral + 230V/650W <b>Product number:</b> 122060-ZSE SDX Thermobox SE150 (4+6 GN 1/1) Single handed grip handle  <b>Product number:</b> 122060-XSE SDX Thermobox SE150 (4+6 GN 1/1) Excenter lock				

### SE180



GUIDES	OUTER	INNER S	INNER E	WEIGHT
4+8 x GN 1/1 80mm spacing	B: 525mm D: 700mm H: 1445mm	B: 330mm D: 540mm H: 350mm	B: 330mm D: 540mm H: 670mm	60 kg
Neutral + 230V/650W <b>Product number:</b> 122105-ZSE SDX Thermobox SE180 (4+8 GN 1/1) Single handed grip handle  <b>Product number:</b> 122105-XSE SDX Thermobox SE180 (4+8 GN 1/1) Excenter lock				

**SE180**



GUIDES	OUTER	INNER S	INNER E	WEIGHT
6+6 x GN 1/1 80mm spacing	W: 525mm D: 700mm H: 1445mm	W: 330mm D: 540mm H: 510mm	W: 330mm D: 540mm H: 510mm	63 kg
Neutral + 230V/650W <b>Product number:</b> 122100-ZSE SDX Thermobox SE180 (6+6 GN 1/1) Single handed grip handle  <b>Product number:</b> 122100-XSE SDX Thermobox SE180 (6+6 GN 1/1) Excenter lock				

**SE210**



GUIDES	OUTER	INNER S	INNER E	WEIGHT
6+8 x GN 1/1 80mm spacing	W: 525mm D: 700mm H: 1605mm	W: 330mm D: 540mm H: 510mm	W: 330mm D: 540mm H: 670mm	67 kg
Neutral + 230V/650W <b>Product number:</b> 122151-ZSE SDX Thermobox SE210 (6+8 GN 1/1) Single handed grip handle <i>Additional pull handles on the sides are included</i>  <b>Product number:</b> 122151-XSE SDX Thermobox SE210 (6+8 GN 1/1) Excenter lock <i>Additional pull handles on the sides are included</i>				

**SE240**



GUIDES	OUTER	INNER S	INNER E	WEIGHT
8+8 x GN 1/1 80mm spacing	W: 930mm D: 700mm H: 1215mm	W: 330mm D: 540mm H: 670mm	W: 330mm D: 540mm H: 670mm	86 kg
Neutral + 230V/650W <b>Product number:</b> 122130-ZSE SDX Thermobox SE240 (8+8 GN 1/1) Single handed grip handle				

**SE360**



GUIDES	OUTER	INNER S	INNER E	WEIGHT
12+12 x GN 1/1 80mm spacing	W: 930mm D: 700mm H: 1355mm	W: 330mm D: 540mm H: 1000mm	W: 330mm D: 540mm H: 1000mm	104 kg
Neutral + 230V/800W <b>Product number:</b> 122046-ZSE SDX Thermobox SE360 (12+12 GN 1/1) Single handed grip handle				



## THERMOBOX® SF

**Exterior walls:** ABS plastic.

**Inner container:** Welded container in stainless steel.

**Guides:** Stainless steel, pressed from the inner container.

**Insulation:** Polyurethane.

**Door:** Internal surface made of smooth and seamless stainless steel. Exterior in ABS plastic.

**Wheels:** 160 mm wheels, two braked and two fixed.

**Top frame:** Stainless steel and PVC corners.

**Trolley frame:** Reject list of stainless steel coated with PVC.

**S:** Neutral.

**F:** Efficient convection heating system, with electronic temperature control, insulation class IP 44, 230V/1000W.

### SF150



GUIDES	OUTER	INNER S	INNER F	WEIGHT
4+6 x GN 1/1 80mm spacing	W: 525mm D: 750mm H: 1285mm	W: 330mm D: 540mm H: 510mm	W: 330mm D: 540mm H: 350mm	62 kg
Neutral + 230V/550W <b>Product number:</b> 122060-ZSF SDX Thermobox SF150 (4+6 GN 1/1) Single handed grip handle  <b>Product number:</b> 122060-XSF SDX Thermobox SF150 (4+6 GN 1/1) Excenter lock				

### SF180



GUIDES	OUTER	INNER S	INNER F	WEIGHT
6+6 x GN 1/1 80mm spacing	W: 525mm D: 750mm H: 1445mm	W: 330mm D: 540mm H: 510mm	W: 330mm D: 540mm H: 510mm	65 kg
Neutral + 230V/550W <b>Product number:</b> 122105-ZSF SDX Thermobox SF180 (6+6 GN 1/1) Single handed grip handle  <b>Product number:</b> 122105-XSF SDX Thermobox SF180 (6+6 GN 1/1) Excenter lock				

### SF210



GUIDES	OUTER	INNER S	INNER F	WEIGHT
4+10 x GN 1/1 80mm spacing	W: 525mm D: 770mm H: 1605mm	W: 330mm D: 540mm H: 830mm	W: 330mm D: 540mm H: 350mm	80 kg
Neutral + 230V/1000W <b>Product number:</b> 122065-ZSF SDX Thermobox SF210 (4+10 GN 1/1) Single handed grip handle <i>Additional pull handles on the sides are included</i>  <b>Product number:</b> 122065-XSF SDX Thermobox SF210 (4+10 GN 1/1) Excenter lock <i>Additional pull handles on the sides are included</i>				

**SF240**

GUIDES                      OUTER                      INNER S                      INNER F                      WEIGHT

8+8 x GN 1/1 80mm spacing	W: 930mm D: 750mm H: 1215mm	W: 330mm D: 540mm H: 670mm	W: 330mm D: 540mm H: 670mm	90 kg
------------------------------	-----------------------------------	----------------------------------	----------------------------------	-------



Neutral + 230V/550W  
**Product number:** 122066-ZSF  
 SDX Thermobox SF240 (8+8 GN 1/1) Single handed grip handle

**SF360**

GUIDES                      OUTER                      INNER S                      INNER F                      WEIGHT

12 + 12 x GN 1/1 80mm spacing	W: 930mm D: 770mm H: 1355mm	W: 330mm D: 540mm H: 1000mm	W: 330mm D: 540mm H: 1000mm	115 kg
----------------------------------	-----------------------------------	-----------------------------------	-----------------------------------	--------



Neutral + 230V/1000W  
**Product number:** 122046-ZSF  
 SDX Thermobox SF360 (12+12 GN 1/1) Single handed grip handle

**SF420**

GUIDES                      OUTER                      INNER S                      INNER F                      WEIGHT

14 + 14 x GN 1/1 80mm spacing	W: 930mm D: 770mm H: 1515mm	W: 330mm D: 540mm H: 1160mm	W: 330mm D: 540mm H: 1160mm	126 kg
----------------------------------	-----------------------------------	-----------------------------------	-----------------------------------	--------



Neutral + 230V/1000W  
**Product number:** 122067-ZSF  
 SDX Thermobox SF420 (14+14 GN 1/1) Single handed grip handle





## THERMOBOX® CE

**Exterior walls:** ABS plastic.

**Inner container:** Welded container in stainless steel.

**Guides:** Stainless steel, pressed from the inner container.

**Insulation:** Polyurethane.

**Door:** Internal surface made of smooth and seamless stainless steel. Exterior in ABS plastic.

**Wheels:** 160 mm wheels, two braked and two fixed.

**Top frame:** Stainless steel and PVC corners.

**Trolley frame:** Rejact list of stainless steel coated with PVC.

**C:** Efficient compact chillers with electronic temperature control AA120/245W, insulation class IP44.

**E:** Patented, efficient heating system, with electronic temperature control Foil elements, insulation class IP 44.

### CE120



GUIDES	OUTER	INNER C	INNER E	WEIGHT
4+4 x GN 1/1 80mm spacing	W: 525mm D: 810mm H: 1310mm	W: 330mm D: 540mm H: 350mm	W: 330mm D: 540mm H: 350mm	70 kg
<p>AA120/245W + 230V/280W  <b>Product number:</b> 122300-ZCE            SDX Thermobox CE120 (4+4 GN 1/1) Single handed grip handle</p> <p><b>Product number:</b> 122300-XCE            SDX Thermobox CE120 (4+4 GN 1/1) Excenter lock</p>				

### CE150



GUIDES	OUTER	INNER C	INNER E	WEIGHT
4+6 x GN 1/1 80mm spacing	W: 525mm D: 810mm H: 1285mm	W: 330mm D: 540mm H: 350mm	W: 330mm D: 540mm H: 510mm	70 kg
<p>AA120/245W + 230V/650W  <b>Product number:</b> 122211-ZCE            SDX Thermobox CE150 (4+6 GN 1/1) Single handed grip handle</p> <p><b>Product number:</b> 122211-XCE            SDX Thermobox CE150 (4+6 GN 1/1) Excenter lock</p>				

### CE180



GUIDES	OUTER	INNER C	INNER E	WEIGHT
4+8 x GN 1/1 80mm spacing	W: 525mm D: 810mm H: 1445mm	W: 330mm D: 540mm H: 350mm	W: 330mm D: 540mm H: 670mm	75 kg
<p>AA120/245W + 230V/650W  <b>Product number:</b> 122203-ZCE            SDX Thermobox CE180 (4+8 GN 1/1) Single handed grip handle</p> <p><b>Product number:</b> 122203-XCE            SDX Thermobox CE180 (4+8 GN 1/1) Excenter lock</p>				

**CE180**



GUIDES	OUTER	INNER C	INNER E	WEIGHT
6+6 x GN 1/1 80mm spacing	W: 525mm D: 810mm H: 1445mm	W: 330mm D: 540mm H: 510mm	W: 330mm D: 540mm H: 510mm	75 kg

AA120/245W + 230V/650W  
**Product number:** 122215-ZCE  
 SDX Thermobox CE180 (6+6 GN 1/1) Single handed grip handle  
  
**Product number:** 122215-XCE  
 SDX Thermobox CE180 (6+6 GN 1/1) Excenter lock

**CE210**



GUIDES	OUTER	INNER C	INNER E	WEIGHT
6+8 x GN 1/1 80mm spacing	W: 525mm D: 810mm H: 1605mm	W: 330mm D: 540mm H: 510mm	W: 330mm D: 540mm H: 670mm	85 kg

AA120/245W + 230V/650W  
**Product number:** 122251-ZCE  
 SDX Thermobox CE210 (6+8 GN 1/1) Single handed grip handle  
*Additional pull handles on the sides are included*  
  
**Product number:** 122251-XCE  
 SDX Thermobox CE210 (6+8 GN 1/1) Excenter lock  
*Additional pull handles on the sides are included*

**CE240**



GUIDES	OUTER	INNER C	INNER E	WEIGHT
8+8 x GN 1/1 80mm spacing	W: 930mm D: 810mm H: 1215mm	W: 330mm D: 540mm H: 670mm	W: 330mm D: 540mm H: 670mm	100 kg

AA120/245W + 230V/650W  
**Product number:** 122262-ZCE  
 SDX Thermobox CE240 (8+8 GN 1/1) Single handed grip handle

**CE360**



GUIDES	OUTER	INNER C	INNER E	WEIGHT
12 + 12 x GN 1/1 80mm spacing	W: 930mm D: 825mm H: 1355mm	W: 330mm D: 540mm H: 1000mm	W: 330mm D: 540mm H: 1000mm	115 kg

AA120/245W + 230V/800W  
**Product number:** 122220-ZCE  
 SDX Thermobox CE360 (12+12 GN 1/1) Single handed grip handle



## THERMOBOX® CF

**Exterior walls:** ABS plastic.

**Inner container:** Welded container in stainless steel.

**Guides:** Stainless steel, pressed from the inner container.

**Insulation:** Polyurethane.

**Door:** Internal surface made of smooth and seamless stainless steel. Exterior in ABS plastic.

**Wheels:** 160 mm wheels, two braked and two fixed.

**Top frame:** Stainless steel and PVC corners.

**Trolley frame:** Reject list of stainless steel coated with PVC.

**C:** Efficient compact chillers with electronic temperature control AA120/245W, insulation class IP44.

**F:** Efficient convection heating system, with electronic temperature control, insulation class IP 44, 230V/1000W.

### CF150



GUIDES	OUTER	INNER C	INNER F	WEIGHT
4+6 x GN 1/1 80mm spacing	W: 525mm D: 810mm H: 1285mm	W: 330mm D: 540mm H: 350mm	W: 330mm D: 540mm H: 510mm	70 kg

AA120/245W + 230V/550W

**Product number:** 122282-ZCF

SDX Thermobox CF150 (4+6 GN 1/1) Single handed grip handle

**Product number:** 122282-XCF

SDX Thermobox CF150 (4+6 GN 1/1) Excenter lock

### CF180



GUIDES	OUTER	INNER C	INNER F	WEIGHT
6+6 x GN 1/1 80mm spacing	W: 525mm D: 810mm H: 1445mm	W: 330mm D: 540mm H: 510mm	W: 330mm D: 540mm H: 510mm	75 kg

AA120/245W + 230V/550W

**Product number:** 122215-ZCF

SDX Thermobox CF180 (6+6 GN 1/1) Single handed grip handle

**Product number:** 122215-XCF

SDX Thermobox CF180 (6+6 GN 1/1) Excenter lock

### CF180



GUIDES	OUTER	INNER C	INNER F	WEIGHT
4+8 x GN 1/1 80mm spacing	W: 525mm D: 810mm H: 1445mm	W: 330mm D: 540mm H: 350mm	W: 330mm D: 540mm H: 670mm	75 kg

AA120/245W + 230V/550W

**Product number:** 122284-ZCF

SDX Thermobox CF180 (4+8 GN 1/1) Single handed grip handle

**Product number:** 122284-XCF

SDX Thermobox CF180 (4+8 GN 1/1) Excenter lock

**CF210**

	GUIDES	OUTER	INNER C	INNER F	WEIGHT
	6+8 x GN 1/1 80mm spacing	W: 525mm D: 810mm H: 1605mm	W: 330mm D: 540mm H: 510mm	W: 330mm D: 540mm H: 670mm	80 kg
	AA120/245W + 230V/550W <b>Product number:</b> 122251-ZCF SDX Thermobox CF210 (6+8 GN 1/1) Single handed grip handle <i>Additional pull handles on the sides are included</i>  <b>Product number:</b> 122251-XCF SDX Thermobox CF210 (6+8 GN 1/1) Excenter lock <i>Additional pull handles on the sides are included</i>				

**CF240**

	GUIDES	OUTER	INNER C	INNER F	WEIGHT
	8+8 x GN 1/1 80mm spacing	W: 930mm D: 810mm H: 1215mm	W: 330mm D: 540mm H: 670mm	W: 330mm D: 540mm H: 670mm	115 kg
	AA120/245W + 230V/550W <b>Product number:</b> 122068-ZCF SDX Thermobox CF240 (8+8 GN 1/1) Single handed grip handle				

**CF360**

	GUIDES	OUTER	INNER C	INNER F	WEIGHT
	12+12 x GN 1/1 80mm spacing	W: 930mm D: 825mm H: 1355mm	W: 330mm D: 540mm H: 1000mm	W: 330mm D: 540mm H: 1000mm	135 kg
	AA120/245W + 230V/1000W <b>Product number:</b> 122220-ZCF SDX Thermobox CF360 (12+12 GN 1/1) Single handed grip handle				

**CF420**

	GUIDES	OUTER	INNER C	INNER F	WEIGHT
	14+14 x GN 1/1 80mm spacing	W: 930mm D: 825mm H: 1515mm	W: 330mm D: 540mm H: 1160mm	W: 330mm D: 540mm H: 1160mm	145 kg
	AA120/245W + 230V/1000W <b>Product number:</b> 122069-ZCF SDX Thermobox CF420 (14+14 GN 1/1) Single handed grip handle				



## THERMOBOX® KE

**Exterior walls:** ABS plastic.

**Inner container:** Welded container in stainless steel.

**Guides:** Stainless steel, pressed from the inner container.

**Insulation:** Polyurethane.

**Door:** Internal surface made of smooth and seamless stainless steel. Exterior in ABS plastic.

**Wheels:** 160 mm wheels, two braked and two fixed.

**Top frame:** Stainless steel and PVC corners.

**Trolley frame:** Rejact list of stainless steel coated with PVC.

**K:** Efficient compressor refrigeration. Eco-friendly refrigerant (R290A) Low-noise, RPM-controlled fans. Digital temperature regulation.

**E:** Patented, efficient heating system, with electronic temperature control Foil elements, insulation class IP 44.

### KE120 ECO



GUIDES	OUTER	INNER K	INNER E	WEIGHT
4+4 x GN 1/1 80mm spacing	B: 525mm D: 750mm H: 1345mm	W: 330mm D: 540mm H: 350mm	W: 330mm D: 540mm H: 350mm	84 kg
230V/190W AC + 230V/650W <b>Product number:</b> 122080-ZKE SDX Thermobox KF120 ECO (4+4 GN 1/1) Single handed grip handle  <b>Product number:</b> 122080-XKE SDX Thermobox KF120 ECO (4+4 GN 1/1) Excenter lock				

### KE150 ECO



GUIDES	OUTER	INNER K	INNER E	WEIGHT
4+6 x GN 1/1 80mm spacing	B: 525mm D: 750mm H: 1505mm	W: 330mm D: 540mm H: 350mm	W: 330mm D: 540mm H: 510mm	89 kg
230V/190W AC + 230V/650W <b>Product number:</b> 122078-ZKE SDX Thermobox KF150 ECO (4+6 GN 1/1) Single handed grip handle  <b>Product number:</b> 122078-XKE SDX Thermobox KF150 ECO (4+6 GN 1/1) Excenter lock				

### KE180 ECO



GUIDES	OUTER	INNER K	INNER E	WEIGHT
6+6 x GN 1/1 80mm spacing	W: 525mm D: 750mm H: 1665mm	W: 330mm D: 540mm H: 510mm	W: 330mm D: 540mm H: 510mm	94 kg
230V/245W AC + 230V/650W <b>Product number:</b> 122072-ZKE SDX Thermobox KE180 ECO (6+6 GN 1/1) Single handed grip handle  <b>Product number:</b> 122072-XKE SDX Thermobox KE180 ECO (6+6 GN 1/1) Excenter lock				

**KE210 ECO**



GUIDES	OUTER	INNER K	INNER E	WEIGHT
6+8 x GN 1/1 80mm spacing	W: 525mm D: 750mm H: 1825mm	W: 330mm D: 540mm H: 670mm	W: 330mm D: 540mm H: 510mm	100 kg
<p>230V/190W AC + 230V/650W  <b>Product number:</b> 122073-ZKE                      SDX Thermobox KE210 ECO (6+8 GN 1/1) Single handed grip handle  <i>Additional pull handles on the sides are included</i></p> <p><b>Product number:</b> 122073-XKE                      SDX Thermobox KE210 ECO (6+8 GN 1/1) Excenter lock  <i>Additional pull handles on the sides are included</i></p>				

**KE240 ECO**



GUIDES	OUTER	INNER K	INNER E	WEIGHT
8+8 x GN 1/1 80mm spacing	W: 930mm D: 750mm H: 1245mm	W: 330mm D: 540mm H: 670mm	W: 330mm D: 540mm H: 670mm	105 kg
<p>230V/190W AC + 230V/650W  <b>Product number:</b> 122074-ZKE                      SDX Thermobox KE240 ECO (8+8 GN 1/1) Single handed grip handle</p>				

**KE360 ECO**



GUIDES	OUTER	INNER K	INNER E	WEIGHT
12+12 x GN 1/1 80mm spacing	W: 930mm D: 770mm H: 1575mm	W: 330mm D: 540mm H: 1000mm	W: 330mm D: 540mm H: 1000mm	115 kg
<p>230V/190W AC + 230V/800W  <b>Product number:</b> 122077-ZKE                      SDX Thermobox KE360 ECO (12+12 GN 1/1) Single handed grip handle</p>				

## THERMOBOX® KF

**Exterior walls:** ABS plastic.

**Inner container:** Welded container in stainless steel.

**Guides:** Stainless steel, pressed from the inner container.

**Insulation:** Polyurethane.

**Door:** Internal surface made of smooth and seamless stainless steel. Exterior in ABS plastic.

**Top frame:** Stainless steel and PVC corners.

**Wheels:** 160 mm wheels, two braked and two fixed.

**Top frame:** Stainless steel and PVC corners.

**Trolley frame:** Reject list of stainless steel coated with PVC.

**K:** Efficient compressor refrigeration. Eco-friendly refrigerant (R290A) Low-noise, RPM-controlled fans. Digital temperature regulation.

**F:** Efficient convection heating system, with electronic temperature control, insulation class IP 44, 230V/1000W.



### KF120 ECO



GUIDES	OUTER	INNER K	INNER F	WEIGHT
4+4 x GN 1/1 80mm spacing	B: 525mm D: 750mm H: 1345mm	W: 330mm D: 540mm H: 350mm	W: 330mm D: 540mm H: 350mm	114 kg
230V/190W AC + 230V/550W <b>Product number:</b> 122221-ZKF SDX Thermobox KF120 ECO (4+4 GN 1/1) Single handed grip handle  <b>Product number:</b> 122221-XKF SDX Thermobox KF120 ECO (4+4 GN 1/1) Excenter lock				

### KF150 ECO



GUIDES	OUTER	INNER K	INNER F	WEIGHT
4+6 x GN 1/1 80mm spacing	B: 525mm D: 750mm H: 1505mm	W: 330mm D: 540mm H: 350mm	W: 330mm D: 540mm H: 510mm	119 kg
230V/190W AC + 230V/550W <b>Product number:</b> 122218-ZKF SDX Thermobox KF150 ECO (4+6 GN 1/1) Single handed grip handle  <b>Product number:</b> 122218-XKF SDX Thermobox KF150 ECO (4+6 GN 1/1) Excenter lock				

### KF180 ECO



GUIDES	OUTER	INNER K	INNER F	WEIGHT
6+6 x GN 1/1 80mm spacing	W: 525mm D: 750mm H: 1665mm	W: 330mm D: 540mm H: 510mm	W: 330mm D: 540mm H: 510mm	124 kg
230V/190W AC + 230V/550W <b>Product number:</b> 122215-ZKF SDX Thermobox KF180 ECO (6+6 GN 1/1) Single handed grip handle  <b>Product number:</b> 122215-XKF SDX Thermobox KF180 ECO (6+6 GN 1/1) Excenter lock				



**KF240 ECO**



GUIDES	OUTER	INNER K	INNER F	WEIGHT
8+8 x GN 1/1 80mm spacing	W: 930mm D: 750mm H: 1245mm	W: 330mm D: 540mm H: 670mm	W: 330mm D: 540mm H: 670mm	132 kg

230V/190W AC + 230V/550W  
**Product number:** 122262-ZKF  
 SDX Thermobox KF240 ECO (8+8 GN 1/1) Single handed grip handle

8 | 8

**KF300 ECO**



GUIDES	OUTER	INNER K	INNER F	WEIGHT
10+10 x GN 1/1 80mm spacing	W: 930mm D: 770mm H: 1430mm	W: 330mm D: 540mm H: 830mm	W: 330mm D: 540mm H: 830mm	140 kg

230V/190W AC + 230V/1000W  
**Product number:** 122219-ZKF  
 SDX Thermobox KF300 ECO (10+10 GN 1/1) Single handed grip handle

10 | 10

**KF360 ECO**



GUIDES	OUTER	INNER K	INNER F	WEIGHT
12+12 x GN 1/1 80mm spacing	W: 930mm D: 770mm H: 1575mm	W: 330mm D: 540mm H: 1000mm	W: 330mm D: 540mm H: 1000mm	150 kg

230V/190W AC + 230V/1000W  
**Product number:** 122220-ZKF  
 SDX Thermobox KF360 ECO (12+12 GN 1/1) Single handed grip handle

12 | 12

**BANQUET**

# BANQUET EDITION FOR GREAT TRANSPORTS



SDX® Thermobox® Banquet is created for you to carry and serve large quantities of food quickly and efficiently. Ideal for stadiums, hotels and conference centers. The box's large volume, combined with several guides creates a flexible and efficient food transport.

**THERMOBOX® S - BANQUET**



GUIDES	OUTER	INNER	WEIGHT
--------	-------	-------	--------

17 x GN 2/1 80mm spacing	W: 790mm D: 890mm H: 1740mm	W: 535mm D: 667mm H: 1405mm	122 kg
-----------------------------	-----------------------------------	-----------------------------------	--------

**Product number:** 122252-ZS  
SDX Thermobox BANQUET S (17 GN 2/1) Single handed grip handle

**TECHNICAL SPECIFICATIONS - S**

**Exterior walls:** ABS plastic.  
**Inner container:** Welded container in aluminium.  
**Guides:** Stainless steel guides with rivets.  
**Insulation:** Polyurethane.

**Door:** Interior made of stainless steel. Exterior in ABS plastic.  
**Wheels:** 160 mm wheels, two braked and two fixed.  
**Trolley frame:** Rejact list of stainless steel coated with PVC.

**THERMOBOX® K - BANQUET**



GUIDES	OUTER	INNER	WEIGHT
--------	-------	-------	--------

13 x GN 2/1 80mm spacing	W: 790mm D: 890mm H: 1740mm	W: 535mm D: 667mm H: 1120mm	138 kg
-----------------------------	-----------------------------------	-----------------------------------	--------

**Product number:** 122252-ZK  
SDX Thermobox BANQUET K (13 GN 2/1) Single handed grip handle

**TECHNICAL SPECIFICATIONS - K**

**Exterior walls:** ABS plastic.  
**Inner container:** Welded container in aluminium.  
**Guides:** Stainless steel guides with rivets.  
**Insulation:** Polyurethane.  
**Door:** Interior made of stainless steel. Exterior in ABS plastic.

**Wheels:** 160 mm wheels, two braked and two fixed.  
**Trolley frame:** Rejact list of stainless steel coated with PVC.  
**K:** Efficient convection cooling with electronic temperature control 230V/190W, insulation class IP44.

**THERMOBOX® F - BANQUET**



GUIDES	OUTER	INNER	WEIGHT
--------	-------	-------	--------

17 x GN 2/1 80mm spacing	B: 790mm D: 890mm H: 1740mm	W: 535mm D: 667mm H: 1405mm	127 kg
-----------------------------	-----------------------------------	-----------------------------------	--------

**Product number:** 122252-ZF  
SDX Thermobox F BANQUET (17 GN 2/1) Single handed grip handle

**TECHNICAL SPECIFICATIONS - F**

**Exterior walls:** ABS plastic.  
**Inner container:** Welded container in aluminium.  
**Guides:** Stainless guides with rivets.  
**Insulation:** Polyurethane.  
**Door:** Interior made of stainless steel. Exterior in ABS plastic.

**Wheels:** 160 mm wheels, two braked and two fixed.  
**Trolley frame:** Rejact list of stainless steel coated with PVC.  
**F:** Efficient convection heating system, with electronic temperature control, insulation class IP 44, 230V/1350W.

## Stationary heating cabinet

Stand-mounted SDX stationary heating cabinets are made of stainless steel and feature convection heating with stepless adjustment up to 90°C.

The interior is made completely of stainless steel, with pressed guides and no joins – a peerless technique that provides unmatched durability and facilitates cleaning. The polyurethane insulation makes the container a well-insulated unit where the food is stored at the right temperature with extremely low energy consumption. Our stationary heating cabinets are fitted with glass doors as standard.



### TECHNICAL SPECIFICATIONS

**Exterior walls:** Stainless.

**Inner container:** Fully welded container in stainless steel.

**Guides:** Stainless, pressed from the inner container.

**Insulation:** Polyurethane.

**Doors:** Glass doors with stainless steel fittings.

**F:** Efficient convection heating system, with electronic temperature control, insulation class IP 44, 230V/1000W.

**F10**

	GUIDES	OUTER	INNER	WEIGHT
	10 GN 1/1 80mm spacing	W: 405mm D: 730mm H: 1225mm	W: 330mm D: 540mm H: 830mm	70 kg
	230V/1000W <b>Product number:</b> 122701 SDX Thermobox Stationary heating cabinet (10 GN 1/1)			

**F12**

	GUIDES	OUTER	INNER	WEIGHT
	12 GN 1/1 80mm spacing	W: 405mm D: 730mm H: 1400mm	W: 330mm D: 540mm H: 1000mm	75 kg
	230V/1000W <b>Product number:</b> 122700 SDX Thermobox Stationary heating cabinet (12 GN 1/1)			

**F14**

	GUIDES	OUTER	INNER	WEIGHT
	14 GN 1/1 80mm spacing	W: 405mm D: 730mm H: 1560mm	W: 330mm D: 540mm H: 1160mm	80 kg
	230V/1000W <b>Product number:</b> 122703 SDX Thermobox Stationary heating cabinet (14 GN 1/1)			

# HEATING CABINET

## Heating cabinet for racking

A well-insulated heating container that makes it simple to hold and transport an entire oven trolley – direct from the oven to the SDX heating cabinet.

The function means versatile and effective handling where there is no need to transfer canteens one at a time. The SDX heating cabinet features convection heating with stepless adjustment up to 90°C. The polyurethane insulation helps keep the food at the right temperature with extremely low energy consumption. Improve efficiency in the kitchen with SDX heating cabinets that keep food warm longer than with conventional thermal protection.



**RATIONAL 201/ELECTROLUX AOS 201**

	HEATING	OUTER	INNER	WEIGHT
	Convection heating 40-90 °C	W: 675mm D: 785mm H: 1778mm	W: 455mm D: 665mm H: 1455mm	173 kg
	<p>SDX Stationary heating cabinet adapted for racking.</p> <p>230V/1350W  <b>Product number:</b> 122550                      SDX Heating cabinet F (Oven trolley) Single-handed grip handle. For racking.</p> <p><b>TECHNICAL SPECIFICATIONS &amp; ACCESSORIES</b></p> <p><b>Exterior walls:</b> Stainless.  <b>Inner container:</b> Container in stainless steel.  <b>Insulation:</b> Polyurethane.  <b>Doors:</b> Glass doors with stainless steel fittings.  <b>Lighting:</b> LED  <b>Wheels:</b> 100 mm wheels, two fixed.</p> <p><b>F:</b> Efficient convection heating system, with electronic temperature control, insulation class IP45, 230V/1350W.  <b>Accessories:</b> Lockable handle. Feet for fixed fitting and marine use.  <b>Supplement:</b> Through and through with two glass doors.</p>			

**TRANSPORT – RATIONAL 201**

	HEATING	OUTER	INNER	WEIGHT
	Convection heating 40-90 °C	W: 780mm D: 1040mm H: 1785mm	W: 455mm D: 665mm H: 1455mm	101 kg
	<p>SDX Mobile heating cabinet adapted for racking.</p> <p>230 V/1350W  <b>Product number:</b> 122650                      SDX Heating cabinet F (Oven trolley) Single-handed grip handle. For racking.  <i>Additional pull handle on the back included.</i></p> <p><b>TECHNICAL SPECIFICATIONS &amp; ACCESSORIES</b></p> <p><b>Exterior walls:</b> ABS plastic.  <b>Inner container:</b> Container in stainless steel.  <b>Insulation:</b> Polyurethane.  <b>Doors:</b> Internal surface made of smooth and seamless stainless steel. Exterior in ABS plastic.  <b>Wheels:</b> 200 mm wheels, two braked and two fixed.</p> <p><b>Trolley frame:</b> Reject list of stainless steel coated with PVC.  <b>F:</b> Efficient convection heating system, with electronic temperature control, insulation class IP45, 230V/1350W.  <b>Accessories:</b> Lockable handle, LED lighting, Glass doors</p>			

**TRANSPORT – ELECTROLUX AOS 201**

	HEATING	OUTER	INNER	WEIGHT
	Convection heating 40-90 °C	W: 780mm D: 1040mm H: 1785mm	W: 455mm D: 665mm H: 1455mm	101 kg
	<p>SDX Mobile heating cabinet adapted for racking.</p> <p>230 V/1350W  <b>Product number:</b> 122600                      SDX Heating cabinet F (Oven trolley) Single-handed grip handle. For racking.  <i>Additional pull handle on the back included.</i></p> <p><b>TECHNICAL SPECIFICATIONS &amp; ACCESSORIES</b></p> <p><b>Exterior walls:</b> ABS plastic.  <b>Inner container:</b> Container in stainless steel.  <b>Insulation:</b> Polyurethane.  <b>Doors:</b> Internal surface made of smooth and seamless stainless steel. Exterior in ABS plastic.  <b>Wheels:</b> 200 mm wheels, two braked and two fixed.</p> <p><b>Trolley frame:</b> Reject list of stainless steel coated with PVC.  <b>F:</b> Efficient convection heating system, with electronic temperature control, insulation class IP45, 230V/1350W.  <b>Accessories:</b> Lockable handle, LED lighting, Glass doors</p>			





# OPTIONAL EXTRAS

We have a wide range of optional extras for the SDX® Thermobox® to create the perfect tool for your food transportation needs.

## Window in the door

Optional glass window in the door allows you to quickly and easily check the contents of your Thermobox® without affecting the temperature.

Product number: 123 017



## Towing truck

For transport by truck. Mounted in the box. (The support wheel used only for single units)

Towing truck

Product number: 149 010

Support wheel

Product number: 123 022

## Ergonomic central brake

Practical and ergonomic central brake simplifies the management of everyday life.

160 mm wheels

Product number: 123 015

200 mm wheels

Product number: 123 031





### Terrain wheels

Product number: 123 027



### Address Card Holder

A6 Product number: 255 001

A5 Product number: 219 028

A4 Product number: 219 026



### Extra handles

Set of 2 pcs.

Product number: 212 011

### Cooling plate

Cooling plate GN 1/1 adapted for Thermobox® S. Including cassette.

Product number: 141 002



### Protection cover

For machine cleaning

Product number: 123 026

### Coil cord

Extra long, 5600mm

Product number:

312 126



## PORTABLE THERMOBOX®

The portable Thermobox® are designed to be compatible with Gastronorm containers, maximum depth 100mm and 200mm respectively.



### S30



#### GUIDES

4 x GN 1/2  
80mm spacing

#### MEASUREMENTS

W: 425mm  
D: 380mm  
H: 415mm

#### WEIGHT

9,5 kg

#### Neutral

Aluminium external walls and all-welded inner container Polyurethane insulation.  
Aluminium door with eccentric lock.

Plastic stacking corners with stainless steel fittings and handles.

**Product number:** 122001 SDX Thermobox S30 (4 GN 1/2)

### E30



#### GUIDES

4 x GN 1/2  
80mm spacing

#### MEASUREMENTS

W: 425mm  
D: 380mm  
H: 415mm

#### WEIGHT

10,5 kg

#### Heating – 230V/145W. IP44

Aluminium external walls and all-welded inner container Polyurethane insulation.  
Aluminium door with eccentric lock.

Plastic stacking corners with stainless steel fittings and handles.

**Product number:** 122002 SDX Thermobox E30 (4 GN 1/2)

### S600



#### GUIDES

4 x GN 1/1  
80mm spacing

#### MEASUREMENTS

W: 425mm  
D: 645mm  
H: 415mm

#### WEIGHT

13 kg

#### Neutral

Aluminium external walls and all-welded inner container Polyurethane insulation.  
Aluminium door with eccentric lock.

Plastic stacking corners with stainless steel fittings and handles.

**Product number:** 122005 SDX Thermobox S600 (4 GN 1/1)

### E600



#### GUIDES

4 x GN 1/1  
80mm spacing

#### MEASUREMENTS

W: 425mm  
D: 645mm  
H: 415mm

#### WEIGHT

14,5 kg

#### Heating – 230V/280W IP44.

Aluminium external walls and all-welded inner container Polyurethane insulation.  
Aluminium door with eccentric lock.

Plastic stacking corners with stainless steel fittings and handles.

**Product number:** 122006-04 SDX Thermobox E 600 (4 GN 1/1)

## PORTABLE THERMOBOX® - Optional extras

Cooling plate

141002

Thermometer in door

123007



# TROLLEYS FOR PORTABLE THERMOBOX AND FLEXI FOR GROCERIES



## H62



MEASUREMENTS	WEIGHT
W: 660mm D: 440mm H: 175mm	5 kg

Adapted for: S600 & E600.  
Maximum load 200kgs.  
Zinc-plated angle profile construction.  
100mm castors, 2 fixed and 2 swivel castors with brakes.  
**Product number:** 131001 SDX H62

## H68



MEASUREMENTS	WEIGHT
W: 470mm D: 670mm H: 200mm (900mm with handle)	13 kg

Adapted for: S600 & E600.  
Maximum load 200kgs.  
Stainless steel construction 18/8.  
125mm castors with rubber track, 2 fixed and 2 swivel castors with brakes.  
**Product number:** 132001 SDX H68

## H78



MEASUREMENTS	WEIGHT
W: 450mm D: 660mm H: 450mm (900mm with handle)	13 kg

Adapted for: S600 & E600.  
Maximum load 200kgs.  
Stainless steel construction 18/8.  
125mm castors with rubber track, 2 fixed and 2 swivel castors with brakes.  
**Product number:** 132002 SDX H78

## H78S



MEASUREMENTS	WEIGHT
W: 480mm D: 660mm H: 630mm (900mm with handle)	17,5 kg

Adapted for: S600 & E600.  
Maximum load 200kgs.  
Stainless steel construction 18/8.  
125mm castors with rubber track, 2 fixed and 2 swivel castors with brakes.  
Top platform – height 630mm. Bottom platform – height 200mm.  
**Product number:** 132003 H78S

## H78S TERRAIN



MEASUREMENTS	WEIGHT
B: 480mm D: 660mm H: 630mm (900mm with handle)	17,5 kg

Adapted for: S600 & E600.  
Maximum load: 200 kgs.  
Stainless steel structure 18/8.  
Top platform – height: 630 mm.  
Bottom platform – height: 200 mm  
**Product number:** 132006 SDX H78S TERRAIN

## FLEXI



EXTERIOR MEASUREMENTS	WEIGHT
W: 435mm D: 695mm H: 1265mm	40 kg

### INNER MEASUREMENTS

W: 405mm  
D: 625mm  
H: 1100mm

The door can be locked in the closed or open position. 125 mm wheels with rubber tires, 2 braked and 2 fixed.  
**Product number:** 135001 SDX Flexi



## Idesta ESS-Norm® containers

As long ago as 1971, IDESTA became the first and only Scandinavian manufacturer to adopt the Gastronorm sizing standard, which is today the self-evident standard for all manufacturers and users of professional kitchen equipment. The Gastronorm system is based on the basic module of 325x530 mm, the sizes of which can be doubled or divided into two, three, four, six or nine parts.

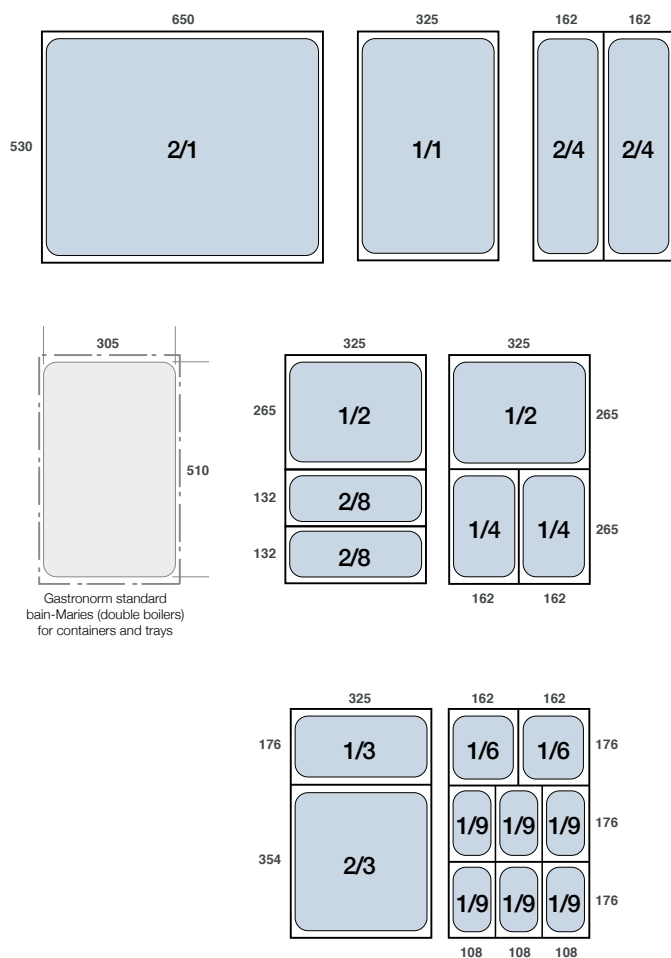

To accommodate the Scandinavian market, Idesta established the, now market leading, ESS-NORM® system, which is compatible with the Gastronorm system.

ESS-NORM® ensures compatibility regarding lid fits and stacking of the different containers. ESS-NORM® containers are manufactured in 0.8 mm high quality 18/8 stainless steel, electrolytically polished to a finish that satisfies the highest hygienic demands. They meet the European Norm for materials used in connection with food processing, EN 631. Features such as lugs to facilitate stacking and foldable handles ensure fulfilment of any demands that can be placed on a stainless steel container. The range is completed with hermetic lids, perforated inserts, lids with and without handles, domed lids etc., making it possible to adapt containers to any requirement.

IDESTA ESS-NORM® implies containers for rational, safe and economical professional kitchen applications. They have unsurpassed durability, which means that operating costs and environmental impact are minimised.



**2/1 - 530 x 650 mm**

		Depth 20 mm	Depth 40 mm	Depth 65 mm	Depth 100 mm	Depth 150 mm	Depth 200 mm
	Containers	70020	70040	70050	70100	-	-
	Containers with handles	-	70041	70051	70101	-	-
	Containers with perforation	-	70042	70052	70102	-	-
	Containers with handles and perforation	-	70043	70053	70103	-	-
	Volume approx litres	-	11	19	28	-	-

**1/1 - 530 x 325 mm**

		Depth 20 mm	Depth 40 mm	Depth 65 mm	Depth 100 mm	Depth 150 mm	Depth 200 mm
	Containers	71020	71040	71050	71100	71150	71200
	Containers with handles	-	71041	71051	71101	71151	71201
	Containers with perforation	71022	71042	71052	71102	71152	71202
	Containers with handles and perforation	-	71043	71053	71103	71153	71203
	Granite enamelled containers	710202	710402	710502	-	-	-
	Fluon® coated containers	715203	715403	710503	-	-	-
Volume approx litres	-	5	9	13,5	20,5	27	

**2/3 - 354 x 325 mm**

		Depth 20 mm	Depth 40 mm	Depth 65 mm	Depth 100 mm	Depth 150 mm	Depth 200 mm
	Containers	72020	72040	72050	72100	72150	72200
	Containers with handles	-	72041	72051	72101	72151	72201
	Containers with perforation	-	72042	72052	72102	72152	72202
	Containers with handles and perforation	-	72043	72053	72103	72153	72203
	Volume approx litres	-	4	6	8,5	13	17,5

# IDESTA ESS-NORM® CONTAINERS

## 1/2 - 325 x 265 mm

		Depth 20 mm	Depth 40 mm	Depth 65 mm	Depth 100 mm	Depth 150 mm	Depth 200 mm
	Containers	73020	73040	73050	73100	73150	73200
	Containers with handles	-	73041	73051	73101	73151	73201
	Containers with perforation	-	73042	73052	73102	73152	73202
	Containers with handles and perforation	-	73043	73053	73103	73153	73203
	Volume approx litres	-	2,5	4	6	9	12

## 2/4 - 530 x 162 mm

		Depth 20 mm	Depth 40 mm	Depth 65 mm	Depth 100 mm	Depth 150 mm	Depth 200 mm
	Containers	73024	73044	73054	73104	-	-
	Containers with handles	-	73045	73055	73105	-	-
	Volume approx litres	-	2	3,5	5,5	-	-

## 1/3 - 176 x 325 mm

		Depth 20 mm	Depth 40 mm	Depth 65 mm	Depth 100 mm	Depth 150 mm	Depth 200 mm
	Containers	74020	74040	74050	74100	74150	74200
	Containers with handles	-	74041	74051	74101	74151	74201
	Volume approx litres	-	1,6	2,5	3,5	5,5	7,5

## 1/4 - 265 x 162 mm

		Depth 20 mm	Depth 40 mm	Depth 65 mm	Depth 100 mm	Depth 150 mm	Depth 200 mm
	Containers	-	-	75050	75100	75150	75200
	Containers with handles	-	-	75051	75101	75151	75201
	Volume approx litres	-	-	1,7	2,5	4,0	5,5

## 2/8 - 132 x 325 mm

		Depth 20 mm	Depth 40 mm	Depth 65 mm	Depth 100 mm	Depth 150 mm	Depth 200 mm
	Containers	-	-	75058	75108	-	-
	Volume approx litres	-	-	1,5	2,7	-	-

## 1/6 - 176 x 162 mm

		Depth 20 mm	Depth 40 mm	Depth 65 mm	Depth 100 mm	Depth 150 mm	Depth 200 mm
	Containers	-	-	76050	76100	76150	76200
	Containers with handles	-	-	76051	76101	76151	76201
	Volume approx litres	-	-	-	1,5	2,5	3,5

## 1/9 - 108 x 176 mm

		Depth 20 mm	Depth 40 mm	Depth 65 mm	Depth 100 mm	Depth 150 mm	Depth 200 mm
	Containers	-	-	77050	77100	-	-
	Volume approx litres	-	-	0,5	1	-	-

1/2

2/4

1/3

1/4

2/8

1/6

1/9



**Lid with handle**

	1/1	2/3	1/2	1/3	1/4	2/8	1/6	1/9
300 standard	71300	72300	73300	74300	75300	75308	76300	77300
301 with wide brim to cover heated wells	71301	-	73301	-	-	-	-	-
320 recess for ladle	71320	72320	73320	74320	75320	-	76320	77320
330 hinged lid	71330	72330	73330	-	-	-	-	-
332 hinged lid with recess for ladle	71332	-	73332	-	-	-	-	-
365 with hermetic seal	71365	72365	73365	74365	75365	-	76365	-
380 dome lid (H 40mm)	71380	-	-	-	-	-	-	-



**Lid without handle**

	2/1	1/1	2/3	1/2	2/4	1/3	1/4	1/6	1/9
340 for low containers	-	71340	72340	73340	73344	74340	75340	76340	77340
350 for trays	-	71350	72350	73350	-	-	-	-	-
385 cook-chill	-	71385	-	-	-	-	-	-	-

**Trays**

	2/1	1/1	2/3	1/2	2/4	1/3	1/4	1/6	1/9
Depth 10 mm	-	71510	72510	73510	-	-	-	-	-
Depth 20 mm	70520	71520	72520	73520	-	-	-	-	-
Depth 40 mm	70540	71540	72540	73540	-	-	-	-	-



## PERFORATED INSERT



### Perforated insert

	1/2 (90 mm deep)	1/2 (140 mm deep)	1/2 (190 mm deep)	2/3 (190 mm deep)	1/1 (90 mm deep)	1/1 (140 mm deep)	1/1 (190 mm deep)
For 100 mm deep containers	73092	-	-	-	71092	-	-
For 100 mm deep containers with handle	73093	-	-	-	71093	-	-
For 150 mm deep containers	-	73142	-	-	-	71142	-
For 150 mm deep containers with handle	-	73143	-	-	-	71143	-
For 200 mm deep containers	-	-	73192	72192	-	-	71192
For 200 mm deep containers with handle	-	-	73193	72193	-	-	71193

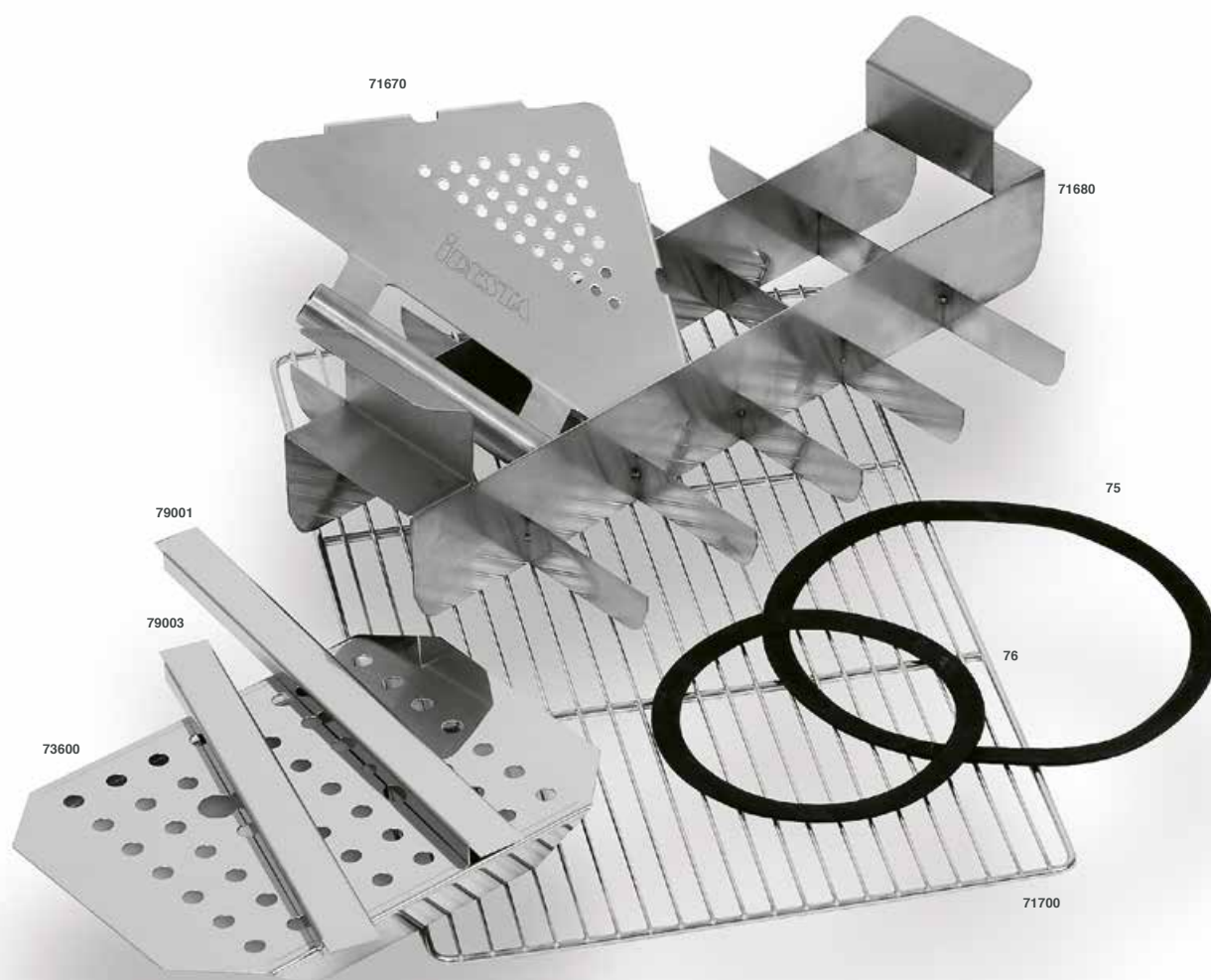

Strainer plate	1/1	2/3	1/2	2/4	1/3	1/4	2/8
	71600	72600	73600	73604	74600	75600	-

Support rail	265 mm	325 mm	530 mm
	79003	79001	79005

Wire Grids	2/1	1/1
Electro polished stainless steel	70700	71700

Portion divider	9-parts	15-parts	18-parts	20-parts	24-parts
GN 1/2	-	-	-	-	-
GN 1/1	-	71679	71680	71681	71682

GN strainer
71670

Lid accessories	1/1	2/3	1/2	2/4	1/3	1/4	2/8	1/6	1/9
Sealing ring for standard lid	71	72	73	-	74	75	-	76	-
Replacement plug for hermetic lid	701	701	701	-	701	701	-	701	-

## Idesta ABC CONTAINERS

IDESTA ABC professional kitchen containers are manufactured according to EN 631 standards. IDESTA's ABC containers are sold worldwide and serve food on all corners of the earth. The nine sizes make it possible to use exactly the right container for the specific preparation, transport or serving purpose.









ABC containers are manufactured in high quality 18/8 stainless steel, electrolytically polished to a finish that satisfies the highest hygienic demands. They fulfil the European Norm for materials used in connection with food processing, EN 631. Extensive service life is guaranteed through the use of 0.8-1 mm thick steel.

They have unsurpassed durability, which means that operating costs and environmental impact are kept to a minimum.

## IDESTA ABC CONTAINERS

				
<b>A - Containers</b>	<b>A-1</b>	<b>A-2</b>	<b>A-3</b>	<b>A Lid</b>
Order no.	42011	42021	42031	42050
Length mm	240	240	240	240
Width mm	240	240	240	240
Depth mm	235	160	75	-
Capacity litres	13,0	9,0	4,0	-

				
<b>B - Containers</b>	<b>B-1</b>	<b>B-2</b>	<b>B-3</b>	<b>B Lid</b>
Order no.	42111	42121	42131	42150
Length mm	155	155	155	155
Width mm	155	155	155	155
Depth mm	235	160	75	-
Capacity litres	5,0	3,5	1,5	-

				
<b>C - Containers</b>	<b>C-2</b>	<b>C-3</b>	<b>C-4</b>	<b>C Lid</b>
Order no.	42221	42231	42241	42250
Length mm	155	155	155	155
Width mm	105	105	105	105
Depth mm	160	75	55	-
Capacity litres	2,5	1,0	0,5	-

A

B

C



# STYLE

## Unique exterior the same quality on the inside

SDX<sup>®</sup> now gives you the opportunity to create a completely unique Thermobox<sup>®</sup> with your own colour and your own logo. Obviously with the same high quality and durability as always.



Standard colours

Choose your colour

Stainless

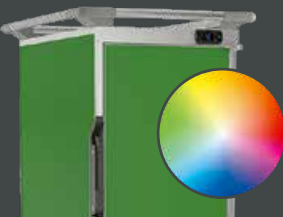

All our Thermobox<sup>®</sup> can be delivered in one of our three standard colours blue, red or black. Timeless colours that suit all environments and settings.

Now you can choose the colour of your Thermobox<sup>®</sup>. To suit your interior or to easily distinguish between different types of boxes.

Both inside and outside in all stainless. A stylish and hygienic choice.



## Sophisticated in both big and small

At SDX® Thermobox® we are both conservative and innovative at the same time. We utilize the latest technology and we listen closely to the wishes of our customers, but we do not make any changes before we are truly convinced that they also bring improvements.

We are meticulous in all aspects should be analyzed. The ergonomic, functional and especially those related to longevity and durability.

We are convinced that the most important thing for you as professional chefs is that you can be sure that the boxes work day after day and the food always keeps the temperature you've decided. There are many reasons to be careful in every detail.

